



(RESEARCH ARTICLE)



Modeling and analysis of exhaust gas recirculation effects on performance and emissions of a single-cylinder agricultural diesel engine

Dinh Xuan Thanh *

Faculty of Transportation Engineering, School of Mechanical and Automotive Engineering, Hanoi University of Industry, Hanoi, Vietnam.

International Journal of Science and Research Archive, 2026, 19(01), 858-868

Publication history: Received on 09 March 2026; revised on 19 April 2026; accepted on 22 April 2026

Article DOI: <https://doi.org/10.30574/ijrsra.2026.19.1.0811>

Abstract

This study investigates the effects of exhaust gas recirculation (EGR) on the performance and emission characteristics of a single-cylinder agricultural diesel engine using a one-dimensional simulation model developed in AVL Boost. The model is constructed based on engine specifications and validated against manufacturer data and experimental measurements, showing good agreement with deviations below 5%. After validation, the model is employed to analyze the influence of EGR under partial load conditions (75% load), which are representative of typical engine operation. The results indicate that increasing the EGR rate leads to a significant reduction in excess air ratio (λ), accompanied by a decrease in combustion temperature and indicated efficiency. Specifically, the peak combustion temperature decreases by approximately 10%, while the indicated efficiency drops by around 10–12% as the EGR rate increases from 0% to 30%. In terms of performance, engine torque decreases slightly (up to 2.65%), whereas brake specific fuel consumption (BSFC) increases by about 7–8%. From an emission perspective, NO_x emissions are significantly reduced by over 90%, while soot emissions increase by approximately 15–18%, highlighting the well-known trade-off between NO_x and particulate matter. An optimal EGR range of 5–15% is identified, where a substantial reduction in NO_x can be achieved with moderate penalties in soot emissions and engine performance. The findings demonstrate that EGR is an effective strategy for NO_x control in agricultural diesel engines; however, its application requires careful optimization to balance emission reduction and engine efficiency.

Keywords: Exhaust gas recirculation; Diesel engine; Emissions; One-dimensional simulation

1. Introduction

Nitrogen oxides (NO_x) are among the most harmful emissions from diesel engines, particularly in turbocharged configurations. The formation of NO_x is primarily associated with the presence of excess oxygen and high combustion temperatures in the combustion chamber. Numerous technologies have been developed and successfully implemented to reduce NO_x emissions, among which exhaust gas recirculation (EGR) is considered one of the most effective solutions.

EGR is widely recognized as an efficient technique for mitigating NO_x formation in diesel engines. In principle, a portion of the exhaust gas leaving the engine is recirculated back into the intake system and mixed with fresh air before entering the combustion chamber. The recirculated exhaust gas mainly consists of carbon dioxide (CO_2), nitrogen (N_2), and water vapor, which act as diluents to reduce oxygen concentration and suppress NO_x formation. Furthermore, the higher specific heat capacity of the recirculated gas increases the overall heat capacity of the intake mixture, leading to a reduction in peak combustion temperature, which is a key factor in limiting thermal NO_x formation [1].

* Corresponding author: Dinh Xuan Thanh

However, despite its effectiveness and relatively low cost, EGR presents several inherent drawbacks. A major limitation is the increase in particulate matter (PM) and soot emissions, especially under high-load conditions [2,3]. In addition, exhaust gas recirculation may lead to lubricant degradation due to contamination by soot and acidic compounds, which accelerates wear of engine components such as pistons and cylinder liners, thereby reducing engine durability [4].

Other disadvantages include increased intake contamination, corrosion risks, reduced volumetric efficiency due to high intake temperature, and deteriorated combustion stability characterized by increased cycle-to-cycle variations. To address these issues, practical EGR systems are typically equipped with EGR coolers, control valves, and filtration or aftertreatment devices to regulate flow and improve gas quality before recirculation [5].

In this study, a one-dimensional computational model is employed to investigate the effects of EGR on the emission characteristics of a turbocharged diesel engine of an older generation. The model is developed using the AVL Boost simulation platform, which enables detailed simulation of the engine working cycle as well as prediction of harmful emission components. The results provide a comprehensive evaluation of the influence of EGR on engine performance parameters and emissions, particularly NO_x and soot.

2. Material and methodology

2.1. Study procedure

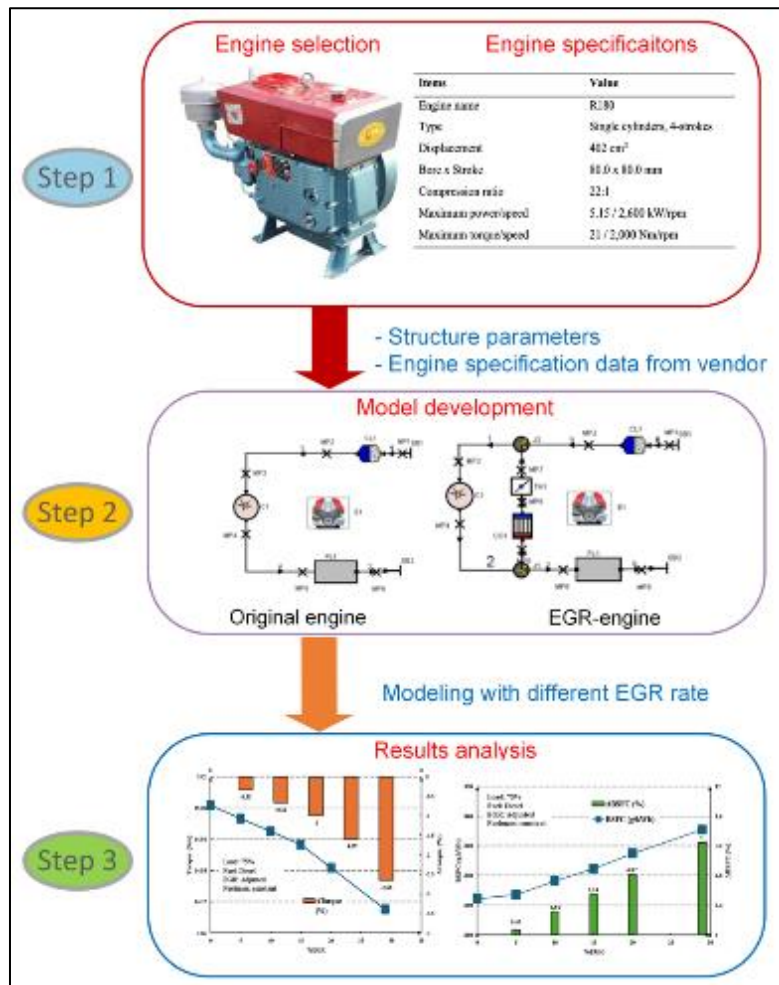

Figure 1 The study procedure flowchart

The research methodology consists of several sequential steps, as illustrated in Figure 1. First, a one-dimensional engine model is developed using the AVL Boost simulation platform, based on technical documentation and the actual structural parameters of a single-cylinder agricultural diesel engine. The model incorporates key inputs such as geometric characteristics, operating conditions, and boundary parameters relevant to typical agricultural applications.

Next, the model is validated to ensure its reliability. The validation process is carried out by comparing key simulated outputs, including engine performance parameters and emission characteristics, with both manufacturer-provided data and experimental measurements obtained from the actual engine. This step ensures that the model can accurately reproduce real engine behavior under representative operating conditions.

After achieving satisfactory agreement, the validated model is employed to investigate the effects of exhaust gas recirculation (EGR). In this study, EGR is primarily applied under low and medium load conditions, which are typical operating regimes for agricultural engines in practice. Various EGR rates are introduced to evaluate their influence on combustion characteristics and emission formation.

Finally, the simulation results are analyzed to assess the impact of EGR on engine performance and emissions, with particular emphasis on NO_x and soot. The findings provide insights into the effectiveness of EGR under practical operating conditions, as well as its associated trade-offs in terms of engine performance and emission behavior.

2.2. Engine specifications

The research object is a single-cylinder agricultural diesel engine, which is widely used in small-scale farming applications due to its simple structure, robustness, and ease of operation. The basic specifications of the engine are summarized in Table 1.

The model development is based on both manufacturer-provided technical specifications and parameters measured from the actual engine. These include key characteristics such as geometric dimensions, operating conditions, and performance-related parameters, ensuring that the model accurately represents real engine behavior.

Based on these inputs, a one-dimensional simulation model of the engine is developed using the AVL Boost platform. The model structure, including the intake system, combustion chamber, and exhaust system, is illustrated in Figure 2.

Table 1 The test engine specifications

Items	Value
Engine name	R180
Type	Single cylinders, 4-strokes
Displacement	402 cm ³
Bore x Stroke	80.0 x 80.0 mm
Compression ratio	22:1
Maximum power/speed	5.15 / 2,600 kW/rpm
Maximum torque/speed	21.0 / 2,000 Nm/rpm

2.3. Governing equations

The emission formation model used in this study is the AVL MCC model. The MCC model is capable of predicting the heat release rate and calculating the main harmful emissions of diesel engines, such as NO_x, soot. According to the MCC model, the heat release rate is determined from both premixed combustion and diffusion combustion processes, as expressed in Equation (1):

$$\frac{dQ_{\square}}{d\alpha} = \frac{dQ_{PMC}}{d\alpha} + \frac{dQ_{MCC}}{d\alpha} \tag{1}$$

The Vibe function is employed to describe the heat release rate during the premixed combustion phase, as shown in Equations (2) and (3):

$$\left(\frac{dQ_{PMC}}{d\alpha}\right) = \frac{a}{\Delta\alpha_c} \cdot (m + 1) \cdot y^m \cdot e^{-a \cdot y^{(m+1)}} \tag{2}$$

$$y = \frac{\alpha - \alpha_{id}}{\Delta\alpha_c} \tag{3}$$

where Q_{PMC} is the heat released during the premixed combustion phase, Q_{MCC} is the heat released during the diffusion combustion phase, α is the crank angle, $\Delta\alpha_c$ is the premixed combustion duration, α_{id} represents the ignition delay period, and m and a are the shape parameters of the Vibe function.

The ignition delay process is modeled based on the Arrhenius and Magnussen approaches. In this approach, the ignition delay α_{id} is defined as the time interval from the start of fuel injection to the onset of combustion. The heat release rate in the diffusion combustion phase is formulated as a function of the fuel mass and the turbulent energy density in the combustion chamber, as expressed in Equation (4):

$$\frac{dQ_{MCC}}{d\alpha} = C_{Comb} \cdot f_1(M_F, Q) \cdot f_2(k, V) \tag{4}$$

Here, C_{comb} is the combustion constant, C_{rate} is the mixing rate constant, k is the turbulent kinetic energy density, M_F is the evaporated fuel mass, LHV is the lower heating value of the fuel, Q is the cumulative heat release, and V is the cylinder volume.

2.4. Simulation model development

When direct experimental measurements are limited or certain in-cylinder processes are difficult to quantify, numerical simulation becomes an effective alternative approach for engine analysis. In this study, the commercial software AVL Boost is employed to develop a one-dimensional model for predicting the influence of operating conditions and technical solutions on the combustion process, in-cylinder characteristics, and overall engine performance, while reducing experimental cost and complexity.

The model structure, as illustrated in Figure 2, is established based on the actual geometric and operating parameters of the engine. The simulation framework is based on the application of the first law of thermodynamics to determine the evolution of in-cylinder pressure throughout the engine cycle.

To represent the combustion process, a fractal-based combustion model is adopted [6]. In addition, wall heat transfer and the variation of thermophysical gas properties with pressure, temperature, and composition are taken into account in the model formulation [7]. These integrated sub-models enable the simulation to reasonably capture the key physical processes occurring inside the engine.

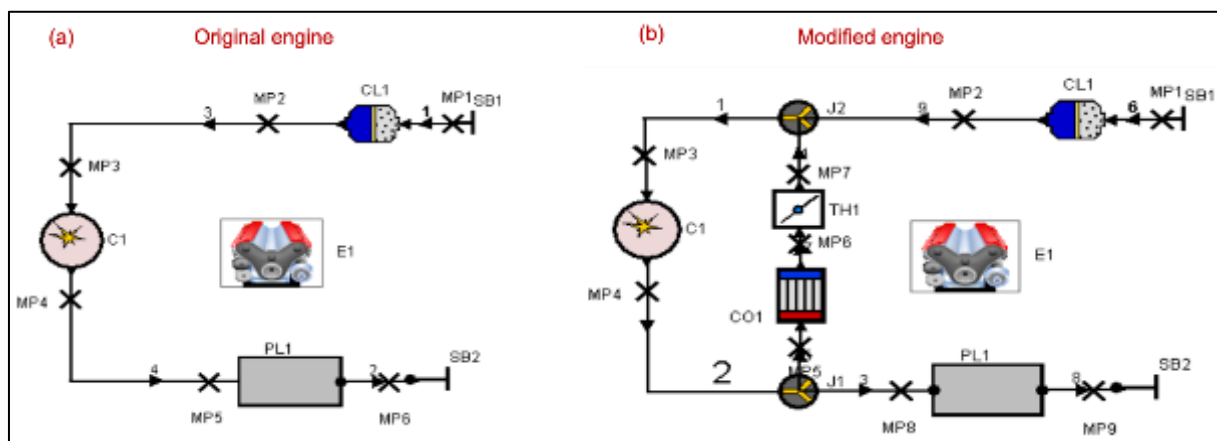

Figure 2 Developed models on AVL Boost

2.5. Simulation scenario

The simulation procedure is carried out through the following steps:

- Step 1: A baseline model of the original engine is first developed using the AVL Boost platform. The model accuracy is evaluated by comparing key simulated results, such as engine performance parameters and operating characteristics, with corresponding experimental measurements. Necessary adjustments are then

performed to ensure that the model achieves an acceptable level of reliability and can accurately represent the real engine behavior.

- Step 2: After validation, the intake and exhaust systems of the engine are modified to incorporate EGR. Based on this modification, EGR configurations are established, as illustrated in Figure 3. In the low-pressure EGR configuration, a portion of the exhaust gas is extracted downstream of the exhaust system and redirected back to the intake manifold, where it mixes with fresh air before entering the engine.
- Step 3: The engine operation is then simulated under intermediate speed and partial load conditions, which are representative of typical working regimes for agricultural engines. The EGR rate is controlled by adjusting the opening of a flow restriction element (denoted as TH1 in the model), allowing different recirculation ratios to be achieved.

The EGR ratio is quantified using the parameter α (%), defined according to Equation (5). Based on this setup, key performance and emission-related parameters are evaluated, including excess air ratio (λ), engine torque, exhaust gas temperature, and thermal efficiency.

$$\alpha = \frac{m_{EGR}}{m_{air}} \times 100\% = \frac{m_{MP7}}{m_{MP3}} \times 100\% \quad (5)$$

Where m_{MP3} and m_{MP7} are the mass flow rates at the measurement points MP3 and MP7, respectively, as shown in Figure 2.

3. Results and discussion

3.1. Validation of simulation models

The baseline engine model is first simulated under full-load conditions to obtain the external characteristic curves. The predicted variations of brake torque and brake power with engine speed are presented in Figure 3. The results show that the model successfully captures the typical performance behavior of the engine: the torque increases with engine speed, reaches a maximum in the intermediate speed range (around 2000 rpm), and then slightly decreases at higher speeds due to reduced volumetric efficiency and increased mechanical losses. In contrast, brake power exhibits a monotonic increase with engine speed, as expected from the combined effect of torque and rotational speed.

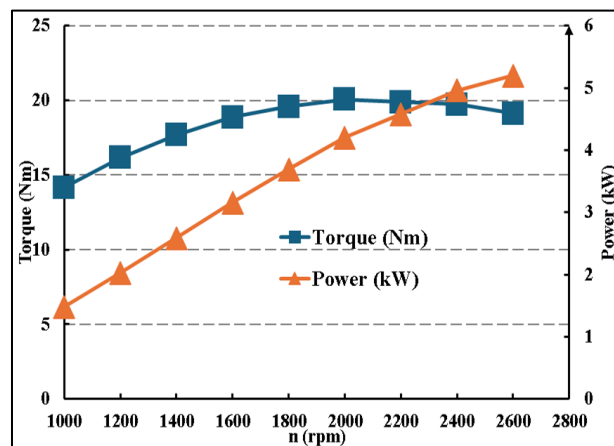

Figure 3 The simulated brake power and torque at full load conditions

To quantitatively evaluate the model accuracy, simulation results are compared with experimental measurements at representative operating conditions, as illustrated in Figure 4. Two key points are selected for validation, including the torque at intermediate speed (2000 rpm) and the brake power at maximum speed (2600 rpm), which are critical for characterizing engine performance. At 2000 rpm, the simulated torque is 20.06 Nm, while the experimental value is 21 Nm, corresponding to a relative deviation of approximately 4.7%. At 2600 rpm, the simulated brake power reaches 5.2 kW, compared to the measured value of 5.15 kW, resulting in a deviation of about 0.96%. It is noted that the deviation in torque is slightly higher than that in power, which may be attributed to the sensitivity of torque prediction to combustion phasing and friction modeling in one-dimensional simulations.

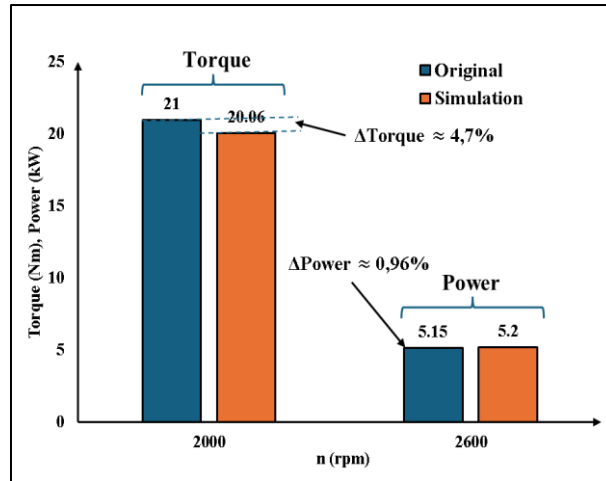

Figure 4 Comparison of brake power and torque at intermediate speed and rate speed

Overall, the deviation between simulated and experimental results remains below 5% for the selected operating points, which is generally considered acceptable for one-dimensional engine modeling. The remaining discrepancies can be explained by uncertainties in input parameters, simplifications in sub-models (such as combustion and heat transfer), and unavoidable variations in experimental conditions.

Despite these limitations, the model demonstrates good agreement with experimental data in both trend and magnitude, confirming its capability to reliably represent the engine behavior. Therefore, the validated model is deemed suitable for subsequent parametric studies on the effects of EGR on engine performance and emission characteristics.

3.2. Effect of EGR rate on excess air ratio (λ)

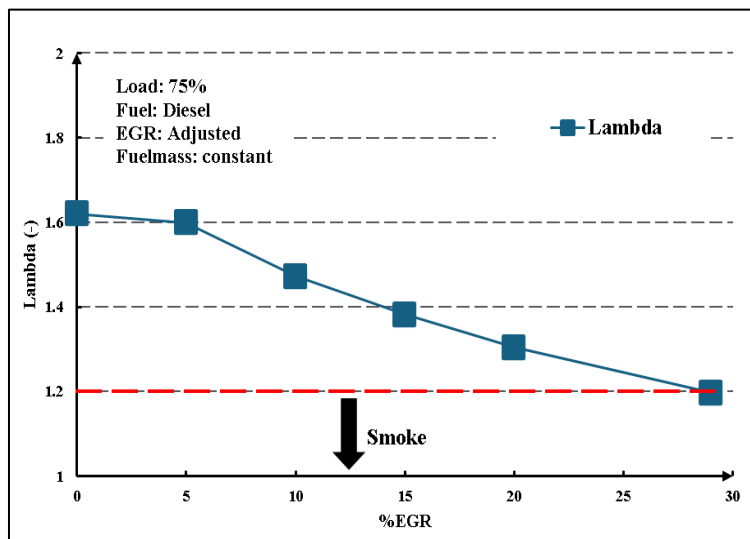

Figure 5 The variation of air excess ratio as a function of EGR ratio

Figure 5 illustrates the variation of the excess air ratio (λ) as a function of the EGR rate under a constant fuel mass condition at 75% load. It can be observed that λ decreases monotonically as the EGR rate increases. Specifically, λ decreases from approximately 1.62 at 0% EGR to about 1.20 at 30% EGR, corresponding to a reduction of nearly 26%.

At low EGR rates (0–5%), the decrease in λ is relatively small, indicating that the intake charge is still dominated by fresh air. However, as the EGR rate increases beyond 10%, λ drops more significantly, reflecting the increasing proportion of recirculated exhaust gas in the intake mixture. This exhaust gas, primarily composed of CO_2 , N_2 , and H_2O , does not contribute to combustion but instead dilutes the oxygen concentration, leading to a lower excess air ratio. This trend is consistent with the fundamental mechanism of EGR reported in previous studies [2,3,5].

From a combustion perspective, the reduction in λ implies a decrease in oxygen availability, which directly affects both combustion efficiency and emission formation. When λ approaches lower values (around 1.2 at 30% EGR), the engine operates closer to locally rich conditions, increasing the tendency for incomplete combustion and soot formation. This is also indicated in Figure 5 by the proximity to the smoke limit line. Similar observations have been reported in the literature, where high EGR rates significantly reduce λ and promote particulate matter formation, especially under medium and high load conditions [3,4,8].

Quantitatively, the relationship between λ and EGR rate in this study shows a nearly linear decreasing trend within the investigated range. This behavior aligns well with previous experimental and simulation studies, which indicate that increasing EGR fraction leads to a proportional reduction in oxygen concentration and excess air ratio [5,8]. However, the rate of decrease becomes more pronounced at higher EGR levels due to the combined effects of intake dilution and reduced volumetric efficiency.

Overall, the results confirm that EGR is an effective method for controlling the in-cylinder oxygen concentration through λ reduction. Nevertheless, excessive EGR may push the engine operation toward the smoke-limited region, resulting in increased soot emissions and degraded combustion stability. Therefore, an optimal EGR rate must be carefully selected to balance NO_x reduction and particulate emission control.

3.3. Effect of EGR on torque and brake specific fuel consumption

Figures 6 and 7 present the variation of engine torque and brake specific fuel consumption (BSFC) as a function of the EGR rate under constant fuel mass conditions at 75% load. It can be observed that increasing the EGR rate leads to a gradual reduction in torque and a corresponding increase in BSFC.

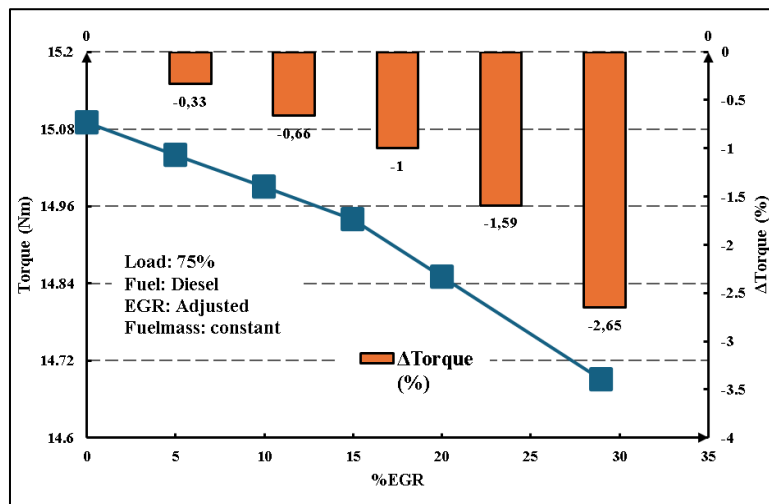

Figure 6 The variation of torque as a function of EGR ratio

In terms of torque, the results show a decreasing trend as the EGR rate increases. Specifically, the torque decreases from approximately 15.08 Nm at 0% EGR to about 14.70 Nm at 30% EGR, corresponding to a reduction of around 2.65%. At low EGR rates (below 10%), the torque reduction is relatively small (less than 1%), indicating that the combustion process is only slightly affected. However, as the EGR rate increases beyond 15%, the torque reduction becomes more pronounced due to the combined effects of reduced oxygen concentration and slower combustion rates.

The reduction in torque can be explained by the dilution effect of EGR, which decreases the oxygen availability and lowers the combustion temperature, leading to a reduction in the rate of heat release and peak cylinder pressure. Additionally, the presence of inert gases (CO_2 , N_2 , and H_2O) increases the specific heat capacity of the mixture, further reducing the effective energy conversion during combustion. Similar trends have been widely reported in previous studies [2,3,5,8].

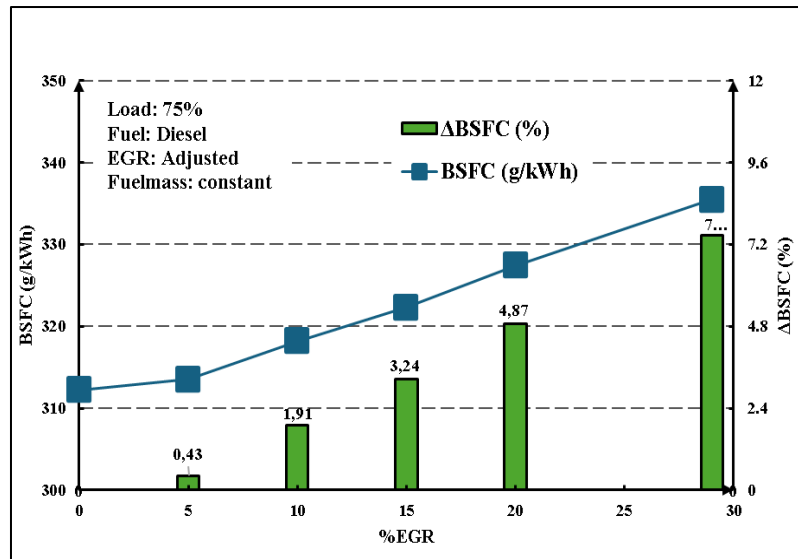

Figure 7 The variation of BSFC as a function of EGR rate

Regarding fuel economy, the BSFC increases consistently with increasing EGR rate. The results indicate that BSFC rises from approximately 312 g/kWh at 0% EGR to about 336 g/kWh at 30% EGR, corresponding to an increase of roughly 7–8%. The relative increase in BSFC (Δ BSFC) becomes more significant at higher EGR rates, reaching approximately 7.2% at 30% EGR.

This increase in BSFC is mainly attributed to the deterioration of combustion efficiency caused by oxygen dilution and lower in-cylinder temperatures. As combustion becomes less complete and slower, more fuel is required to produce the same output power. In addition, the reduced volumetric efficiency due to higher intake gas temperature further contributes to the decline in engine efficiency. These findings are consistent with those reported in the literature, where EGR is shown to negatively impact fuel consumption, particularly at medium and high load conditions [3,4,9].

Overall, the results highlight a clear trade-off between emission control and engine performance. While EGR is effective in reducing NO_x emissions, it leads to a penalty in torque and fuel economy. Therefore, the EGR rate must be carefully optimized to balance emission reduction and engine performance.

3.4. Effect of EGR on combustion temperature and efficiency

Figure 8 illustrates the variation of the maximum burned zone temperature and indicated efficiency as a function of the EGR rate under constant fuel mass conditions at 75% load. It can be clearly observed that both parameters decrease with increasing EGR rate.

Specifically, the peak combustion temperature decreases from approximately 2680 K at 0% EGR to about 2420 K at 30% EGR, corresponding to a reduction of nearly 10%. This behavior is primarily attributed to the dilution effect of recirculated exhaust gases, which consist mainly of CO_2 , N_2 , and H_2O . These gases have higher specific heat capacities than fresh air, thereby reducing the temperature rise during combustion. In addition, the reduced oxygen concentration further suppresses the combustion intensity. Similar trends have been widely reported in previous studies [2,5,8,10,11].

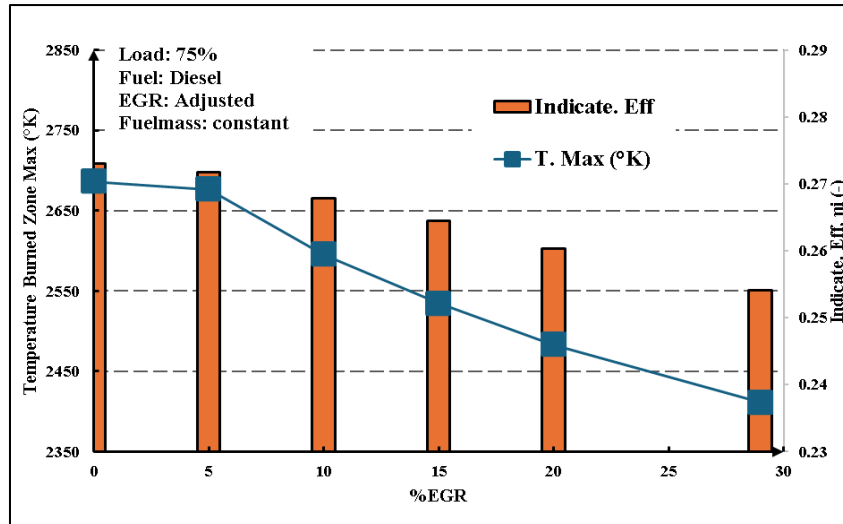

Figure 8 The variation of indicated efficiency and combustion temperature as a function of EGR rate

In parallel, the indicated efficiency shows a gradual decline with increasing EGR rate. The results indicate that the efficiency decreases from approximately 0.27 at 0% EGR to around 0.24 at 30% EGR, representing a reduction of about 10–12%. This reduction can be explained by the deterioration of combustion quality under diluted conditions, including slower combustion rates, incomplete fuel oxidation, and increased heat losses. Furthermore, the reduction in volumetric efficiency due to higher intake gas temperature also contributes to the decrease in overall engine efficiency [3,4,9,10].

Overall, the results confirm that while EGR effectively reduces combustion temperature, it also leads to a penalty in engine efficiency, particularly at higher EGR rates.

3.5. Effect of EGR on NO_x and soot emissions

Figure 9 presents the variation of NO_x and soot emissions with respect to the EGR rate under the same operating conditions. A clear trade-off between NO_x reduction and soot formation can be observed.

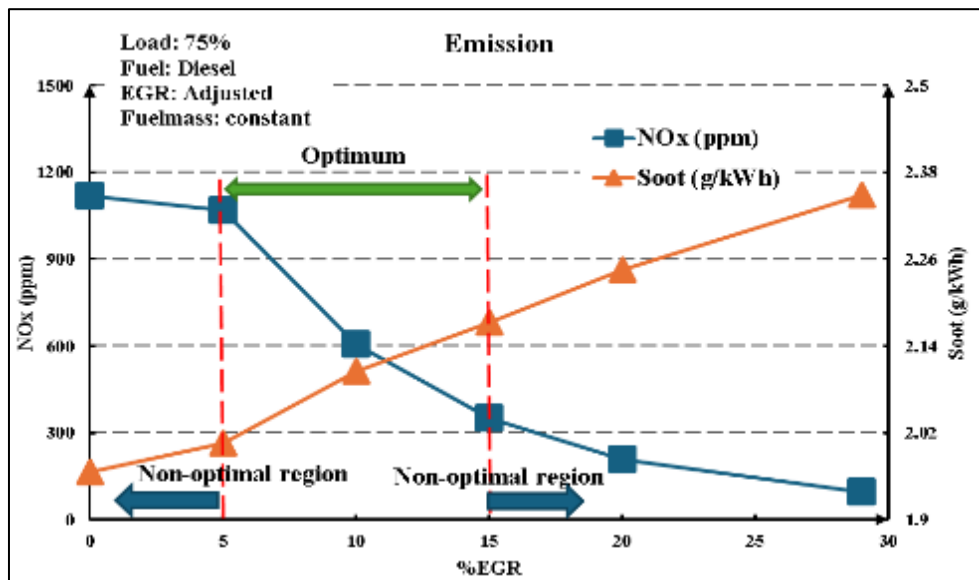

Figure 9 The variation of NO_x and soot as a function of EGR rate

As the EGR rate increases, NO_x emissions decrease significantly. The NO_x concentration drops from approximately 1100 ppm at 0% EGR to below 100 ppm at 30% EGR, corresponding to a reduction of over 90%. This strong decrease is mainly due to the reduction in peak combustion temperature and oxygen concentration, which are the dominant factors

governing thermal NO formation. These findings are consistent with previous studies on EGR effects in diesel engines [2,5,8,11].

In contrast, soot emissions increase steadily with increasing EGR rate. The soot level rises from approximately 2.0 g/kWh at low EGR rates to about 2.35 g/kWh at 30% EGR, reflecting an increase of around 15–18%. This behavior is attributed to the reduced oxygen availability and lower combustion temperature, which limit the oxidation of soot precursors and promote particulate formation. Similar trends have been reported in the literature [3,8,9,12].

Based on the combined analysis, an optimal EGR range can be identified. As shown in Figure 9, the EGR range of approximately 5–15% provides a favorable compromise, where NO_x emissions are significantly reduced while the increase in soot and the deterioration in engine performance remain moderate. At lower EGR rates (<5%), the NO_x reduction is limited, whereas at higher EGR rates (>15%), the increase in soot emissions becomes significant. These results highlight the inherent trade-off between NO_x and soot emissions in diesel engines and emphasize the need for careful optimization of the EGR rate to achieve balanced emission control.

Nomenclature

CO	Carbon monoxide
NO _x	Nitrogen oxides
HC	Hydrocarbons
CO ₂	Carbon dioxide
λ	Excess air ratio
α	EGR rate (%)

4. Conclusion

The main conclusions of this study can be summarized as follows:

- A one-dimensional simulation model of a single-cylinder agricultural diesel engine was successfully developed using AVL Boost and validated against experimental and manufacturer data, with deviations below 5%, confirming its reliability for further analysis.
- Increasing the EGR rate leads to a significant reduction in excess air ratio, resulting in lower oxygen availability and a dilution effect in the combustion process.
- The peak combustion temperature decreases by approximately 10% as the EGR rate increases from 0% to 30%, which contributes to the effective suppression of NO_x formation.
- Indicated efficiency decreases by about 10–12%, while engine torque shows a slight reduction (up to 2.65%) and BSFC increases by approximately 7–8%, indicating a performance penalty associated with EGR application.
- NO_x emissions are significantly reduced (over 90%), whereas soot emissions increase by around 15–18%, confirming the inherent trade-off between NO_x and particulate matter in diesel combustion.
- An optimal EGR range of 5–15% is identified, providing a good compromise between NO_x reduction and acceptable levels of soot emissions and performance degradation.

The results suggest that while EGR is an effective and practical solution for NO_x control, its application should be combined with appropriate optimization strategies or aftertreatment systems to achieve balanced emission reduction.

Compliance with ethical standards

Acknowledgments

The authors would like to acknowledge that this research did not receive any specific grant from funding agencies in the public, commercial, or not-for-profit sectors.

Disclosure of Conflict of Interest

The authors declare that there is no conflict of interest.

References

- [1] Yokomura, H., Kohketsu, S., Mori, K. EGR system in a turbocharged and intercooled heavy-duty diesel engine – expansion of EGR area with venturi EGR system. SAE Tech. Pap. 2005-01-0134 (2005). doi:10.4271/2005-01-0134
- [2] Agarwal, A.K., Singh, A.P., Maurya, R.K. Evolution, challenges and path forward for low temperature combustion engines. Prog. Energy Combust. Sci. 61 (2017) 1–56. doi:10.1016/j.pecs.2017.02.001
- [3] Rajendran, M., Ganesan, V. Effect of exhaust gas recirculation (EGR) on performance, combustion and emission characteristics of diesel engine – A review. Fuel 262 (2020) 116143. doi:10.1016/j.fuel.2019.116143
- [4] Rakopoulos, Z.C., Rakopoulos, C.D., Giakoumis, E.G. Diesel engine transient operation and emissions: A review. Energy Convers. Manage. 180 (2019) 117–135. doi:10.1016/j.enconman.2018.10.073
- [5] Huang, Z., Liu, B., Zeng, K. Effect of EGR on combustion and emissions in diesel engines: A review. Appl. Energy 165 (2016) 92–111. doi:10.1016/j.apenergy.2015.12.032
- [6] AVL List GmbH. AVL BOOST combustion model. BOOST user’s guide. Graz, Austria (2011).
- [7] AVL List GmbH. Thermodynamic cycle simulation BOOST, version 3.2. BOOST user’s guide. Graz, Austria (2011).
- [8] Ladommatos, N., Abdelhalim, S.M., Zhao, H., Hu, Z. The effects of exhaust gas recirculation on combustion and emissions in diesel engines. Int. J. Engine Res. 1 (2000) 107–126. doi:10.1243/1468087001545290
- [9] Heywood, J.B. Internal combustion engine fundamentals, 2nd ed., McGraw-Hill, New York (2018).
- [10] Millo, F., Ferraro, C.V., De Filippo, A. Impact of EGR on performance and emissions of a turbocharged diesel engine. Appl. Energy 178 (2016) 384–394. doi:10.1016/j.apenergy.2016.06.089
- [11] Kook, S., Pickett, L.M. Effect of cooled EGR on diesel combustion and emissions under low-temperature combustion conditions. SAE Int. J. Engines 2 (2009) 171–186. doi:10.4271/2009-01-2646
- [12] Tree, D.R., Svensson, K.I. Soot processes in compression ignition engines. Prog. Energy Combust. Sci. 33 (2007) 272–309. doi:10.1016/j.pecs.2006.03.002