



(RESEARCH ARTICLE)



## Optimal control algorithms for Gabon's Smart Grid: Enhancing efficiency and sustainability

Loundou Ndonga Elsi Othniel \*, Jing Chen, Nguembi Ines Pamela and Marcel Merimee Bakala Mboundou

*Anhui university of science and technology, school of Electrical and Information. No.168 Taifeng Road, Huainan, 232001, China.*

International Journal of Science and Research Archive, 2024, 13(01), 319–333

Publication history: Received on 24 July 2024; revised on 29 August 2024; accepted on 31 August 2024

Article DOI: <https://doi.org/10.30574/ijrsra.2024.13.1.1576>

### Abstract

The adoption of smart grid technologies offers Gabon several opportunities to enhance energy efficiency and sustainability. This study investigates the use of optimum control algorithms to increase grid stability and enhance the utilization of renewable energy sources. Mathematical models and simulations are used to assess genetic algorithms in light of Gabon's unique energy situation. Systems known as electrical smart grids supply electricity to users directly from power plants in an effort to reduce costs, cut down on blackouts, and improve energy efficiency. Smart grids, or SGs, are well-known pieces of equipment because of their amazing capabilities, which include bi-directional communication, stability, power failure detection, and interconnectivity with appliances for monitoring. Many modern data and security management systems, including modeling, monitoring, optimization, and/or artificial intelligence, lead to SGs. Energy was once cheap, easily managed, and dependent only on fundamental elements. Demand has significantly increased as a result of the current circumstances, which has also increased Gabon's electricity expenses, the likelihood of a contingency, and the complexity of the electrical network. In Gabon, smart grids have shown to be the most practical and clever way to lessen these problems in recent years. An electrical network with information technology integrated is called a smart grid. According to this study, using genetic algorithms in a smart grid could lower Gabon's overall electricity prices. In order to meet demand, the proposed approach makes use of off-grid battery banks and renewable energy sources. The goal of GA optimization is the short-term time averaged power cost; factors that affect this include grid energy to satisfy load, battery discharge, and other factors. MATLAB software is used to solve the optimization problem over a 24-hour period of renewable input, real-time energy pricing, and load. The results are presented.

**Keywords:** Real-time pricing; Energy storage; Smart grid; Grid optimization; Genetic algorithm optimization

### 1. Introduction

By combining cutting-edge technologies to monitor, control, and optimize energy usage, the idea of smart grids has completely changed the way energy is managed. Energy security and sustainability in Gabon depend on optimizing smart grid operations, as the country's energy infrastructure is changing quickly. This paper looks into optimal control algorithms as a way to help Gabon's smart grid system overcome its dynamic issues.

The global community has been increasingly focused on energy-related issues due to the evident connection between energy consumption and environmental issues. Nations have enacted legislation focused on energy conservation and environmental preservation, which encourages and supports the use of energy-saving practices to tackle this issue. Stadiums and other entities that consume huge amounts of energy necessitate support not only in managing energy usage but also in implementing steps to adapt to changing circumstances. In order to guarantee the sufficient energy required for events, games, and other activities, it is crucial to have a comprehensive understanding of energy

\* Corresponding author: Loundou Ndonga Elsi Othniel

management. The advancement of smart grid technology has emerged as an innovative remedy for energy management challenges in sports stadiums, owing to continuous advancements in big data, the Internet of Things, smart technology, and related fields. The smart grid (SG) is a highly advanced tool that is increasingly being adopted worldwide to enhance the efficiency of the electrical grid. These networks enable the transmission of electricity and information, while also utilizing the data to enhance decision-making. Smart grid technology employs deep learning artificial intelligence, sophisticated data analytics, intelligent control, and energy optimization methodologies to accurately forecast and optimize energy use in sports stadiums. This will accomplish several overarching objectives, encompassing economic advantages, environmental preservation, and energy efficiency. The potential energy-saving applications of smart grid technologies in sporting facilities have garnered significant interest.

Electric grids that supply electricity to consumers (residential and industrial) from utilities (power generation sources/companies) are referred to as smart grids. With the aid of several intelligent features like artificial intelligence (AI) or computational intelligence (CI), the delivery of energy can be monitored, modeled, controlled, filtered, and processed, as seen in Figure 1. By allowing users to plan appliances based on pricing hours and demand, smart grids (SGs) reduce energy consumption, improve dependability, and cut expenses. [1], [2]. Moreover, SGs facilitate wireless and bidirectional power line communications, including ZigBee, 6LowPAN, Z-wave, Internet of There are three types of networks: Things networks, Home Area Networks (HAN), and Wide Area Networks (WAN). The range is from 3 to 6.

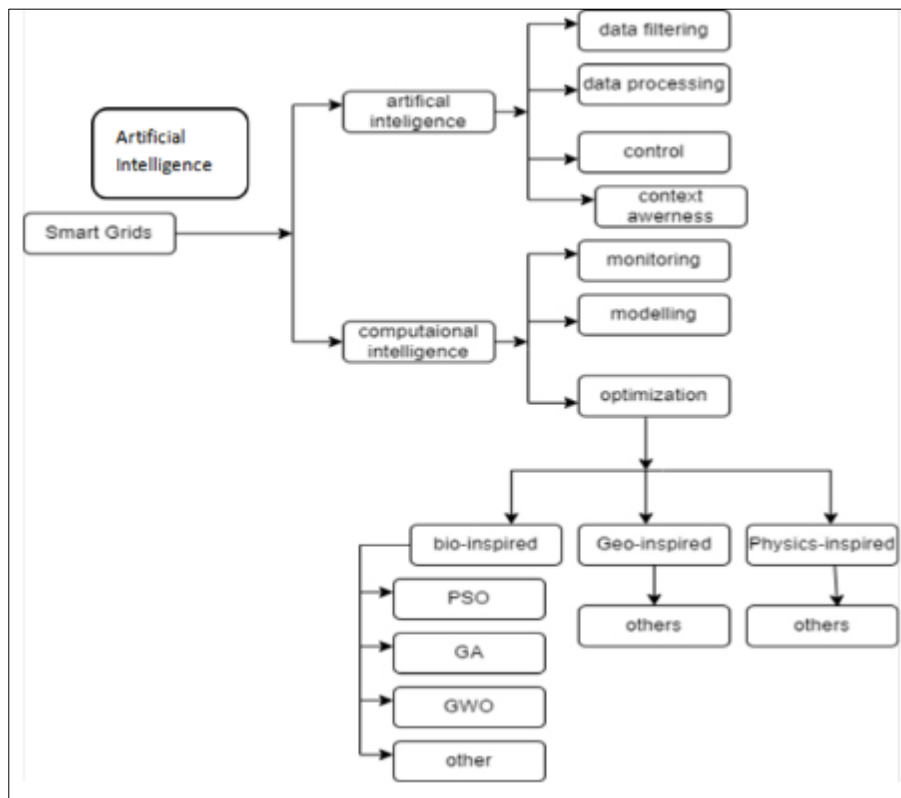

**Figure 1** Classification of intelligence in smart grids

A smart grid is a network that uses optimization techniques to reduce voltage levels, network losses, and better management through real-time measurement. It is a sensor-based system with computational power and the capacity to integrate people who are connected to it. The goal of the smart grid is to facilitate generators' actions and connections by managing transmissions and monitoring. From an energy efficiency perspective, it benefits both the consumer demand and the power grid. The automation technology of the computerized smart grid, which enables the movement of millions or even individual pieces of equipment from a prominent position, is a crucial element. The addition of electric vehicles and intermittent renewable energy sources to the grid would also be facilitated by smart grid technology.

The smart grid consists of two types of energy demands: elastic and inelastic. This article analyzes the implementation of a smart grid that incorporates renewable energy sources, energy-storing battery banks, and inelastic demand to effectively decrease the average cost of power over a short period of time. The decision-making process considers four

factors: battery discharge, grid energy consumption to meet the load, grid energy consumption for battery charging, and a control variable that determines the quantity of renewable energy utilized. The Genetic Algorithm in MATLAB software is utilized to do multi-variable, single-objective optimization for real-time data on power price, renewable energy inputs, and the utilities' overall energy usage. The most accurate power cost estimates over time for different types of batteries. The smart grid system under study is fully modeled, the stochastic problem is established, an extensive optimization technique is applied, system data is supplied, and results are generated in the section that follows.

### 1.1. Research Objectives of the Study

Research objectives of our study are;

- Create and put into practice the best control algorithms suited to the unique needs and limitations of Gabon's smart grid system. Enhancing the energy distribution system's sustainability, dependability, and efficiency should be the main goals of these algorithms.
- Create plans and controls to ensure that renewable energy sources, such wind and solar energy, are optimally integrated into Gabon's smart grid. In order to provide a steady and dependable power supply, this involves controlling variability and intermittency.
- Examine and enhance the smart grid's functionality to lower energy waste and running expenses. To improve the grid's total efficiency, this entails utilizing adaptive control, real-time monitoring, and predictive analytics.
- Look into and put into effect control measures that promote sustainable energy practices among producers and consumers. Demand response plans, energy storage options, and systems of incentives to encourage the use of clean and renewable energy sources are examples of this.

### 1.2. Research Questions of the Study

Research questions of the study are;

- How can optimal control algorithms be developed and put into practice to improve the effectiveness and dependability of Gabon's smart grid infrastructure? is the first research topic of the study.
- How can renewable energy sources be efficiently integrated into Gabon's smart grid to reduce unpredictability and intermittency and guarantee a steady supply of electricity?
- What real-time monitoring and predictive analytics strategies can be used to lower energy losses and operating expenses in Gabon's smart grid?

### 1.3. Innovative Aspects of the Study

The innovative aspects of our study based on

- **Development of Advanced Predictive Analytics Models:** This involves developing complex predictive models that forecast energy demand, supply variations, and grid performance by utilizing artificial intelligence and machine learning. These models will be customized to fit the particulars of Gabon's energy usage and infrastructure.
- **Real-Time Data Integration and Analysis:** Setting up a complete system for real-time monitoring that combines information from multiple sources, such as weather stations, smart meters, renewable energy sources, and grid sensors. This system will make it possible to analyze data continuously and react quickly to changes in the operational state of the grid.
- **Adaptive Control Mechanisms:** Development and application of algorithms for adaptive control that can modify grid operations in real time on the basis of data that is collected in real time and forecast information. These algorithms will guarantee effective resource usage, minimize losses, and optimize energy distribution.
- **Energy Loss Detection and Mitigation:** This section introduces novel methods for locating and reducing energy losses within the system. This includes proactive maintenance scheduling to avoid energy waste, sophisticated defect detection techniques, and anomaly detection in energy usage patterns.
- **Cost-Optimization Techniques:** Creating cost-optimization techniques that make use of predictive analytics to find areas where energy production, delivery, and consumption can be made more affordable. This entails eliminating operating inefficiencies, lowering peak demand, and maximizing the usage of renewable energy sources.
- **Easy-to-use Dashboards and Decision Support systems:** Development of user-friendly dashboards and decision support systems that offer policymakers and grid operators practical insights from predictive analytics. These

technologies will improve the overall administration of the smart grid and make it easier to make well-informed decisions.

- Scalability and Flexibility: Ensuring the scalability and flexibility of the predictive analytics and real-time monitoring approaches to enable their adaptation and expansion in tandem with the evolution of Gabon's smart grid and the emergence of new technologies.

The study intends to greatly improve Gabon's smart grid's sustainability, dependability, and efficiency by including these cutting-edge elements. This would eventually result in less energy losses and lower operating expenses.

Our paper is organized as in section 2 we give related work and the description of the system, in section 3 Methodology we discuss about the formulation of the problem, and their mathematical form, in section 4 results and discussion part we show the optimization and innovative algorithm and their simulations results on MATLAB. Section 5 we conclude our study.

## 2. Literature Review

In their study, Akinyele *et.al.*, [3], investigated how to integrate renewable energy sources into the electricity grids of African nations, emphasizing the difficulties and potential fixes for improving sustainability and efficiency. Model Predictive Control (MPC), which was introduced by Qin *et.al.*, [4], has been extensively researched for its potential applications in smart grid management. In particular, it has received attention for its capacity to manage multivariable control limitations and difficulties in real-time. In their study, Gandomkar, *et.al.*, [5], demonstrate how Genetic Algorithms (GA) may be used to place and size distributed energy resources (DERs) optimally, improving grid efficiency and dependability.

Utilizing optimal control algorithms, Bahramirad, *et.al.*, [6], suggested designing and implementing energy management systems (EMS) for microgrids to govern energy storage, load balancing, and renewable energy integration. [7], Conejo, *et.al.*, state that stochastic optimization approaches are used to manage the uncertainties in load demand and renewable energy output, guaranteeing dependable and effective grid operations. Liu, *et.al.*, [8], put forth and to increase the dependability and effectiveness of smart grids, sophisticated real-time monitoring and fault detection techniques have been researched.

[9], Palensky, *et.al.*, describe how to balance supply and demand, lower peak loads, and enhance grid stability through the use of optimal control algorithms in their study on demand response and load management tactics. The possibilities and difficulties of implementing smart grid technology in African nations were highlighted by Amankwah-Amoah, J. [10], with an emphasis on expanding access to power and incorporating renewable energy sources. Studies evaluating the financial and ecological advantages of deploying smart grid technologies, such as lower expenses, lower emissions, and increased energy efficiency, were conducted by Brown, *et.al.*, in [11]. Momoh, J. A. [12], discusses in their paper how different optimization techniques such as heuristic algorithms, dynamic programming, and linear programming have been researched for their potential to improve sustainability and efficiency in smart grid operations.

Many different approaches and applications are presented in the literature on optimum control algorithms for smart grids, with the goal of improving sustainability, dependability, and efficiency. Despite the fact that these studies offer insightful analysis and frameworks that can be tailored to the unique requirements and limitations of Gabon's smart grid. Gabon can accomplish sustainable energy goals, enhance its energy infrastructure, and incorporate renewable energy sources by utilizing sophisticated control algorithms, real-time monitoring, and predictive analytics.

### 2.1. Description of the System

This study examines a smart grid system in which users generate their own energy and are connected to the electrical grid, as well as having a battery bank for energy storage. Fig. 2 shows the battery bank, or energy storage system, that stores the generated renewable energy. Regular charging and draining will shorten a battery's operational life. A controller is required to prevent overcharging and over discharging from damaging the battery. The battery's operation, including how quickly it charges and discharges, is managed by the controller. A connected inverter transforms DC to AC before the appliances are powered on. The ensuing subsections provide a detailed explanation of each system component.

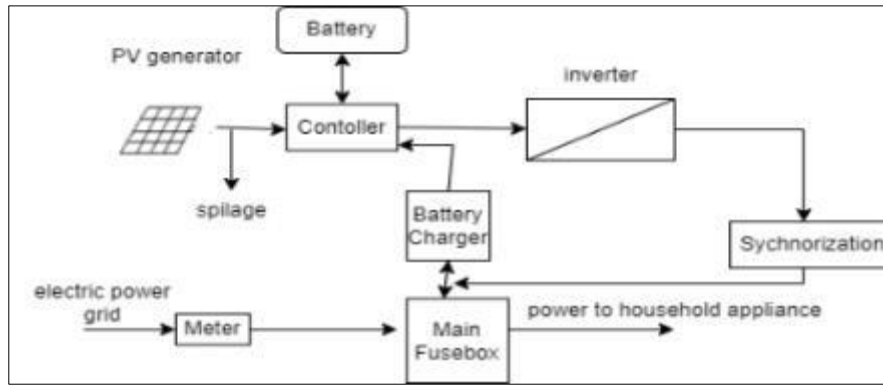

Figure 2 Semantics of the smart grids

## 2.2. Renewable Energy Generation

This system harnesses solar energy as its source of renewable energy. The energy source's output is assumed to be available for every time slot  $t$ , which corresponds to one hour. This study does not consider the intricate modeling of the photovoltaic panels.  $S(t)$  represents the quantity of renewable energy produced during a specific time interval, referred to as time slot  $t$ . In the upcoming part, we will examine a decision variable that regulates the quantity of renewable energy that is utilized. One of the remaining parts contains a visual representation that shows the amount of renewable energy produced each day.

## 2.3. Battery Bank: Energy Storage

A battery bank allows users to store energy produced by renewable sources for later use. Unused batteries tend to gradually lose a portion of their stored energy. This component of the battery is disregarded in order to maintain simplicity.  $SOC(t)$ , also known as the State of Charge at a specific time slot  $t$ , represents the battery's current level of charge.  $B(t)$  denotes the level of charge in a battery in this study. The battery is capable of managing the majority of the inelastic load analyzed in this experiment. When deemed required and when the cost of electricity is reasonable, the battery is charged by utilizing both electricity from the power grid and the portion of electricity generated from renewable sources that belongs to the consumer. To fulfill the specified conditions, the amount of electricity drawn from the power grid to charge the battery  $G_b(t)$  is adjusted dynamically during the optimization procedure. The energy that may be obtained from the battery to fulfill the load during each time slot  $t$  is represented by the maximum discharge rate, or  $D_{max}$ , denoted as  $D(t)$ . Here are the complete formulas for determining the state of charge (SOC) level for the next time interval.

## 2.4. Energy Demand

This study indicates that consumer-side demand is inelastic, meaning that it only occurs seldom and for brief periods of time, and when it does, it must be immediately satisfied. This is mainly intended to be accomplished through the use of batteries; energy is directly received from the grid in the event that the battery is insufficient to fulfill demand. With  $G_I(t)$ , we can see how much power needs to be purchased from the grid to satisfy demand. The following parts provide the 24-hour demand that the optimization approach is applied to. The main goal of optimization is to minimize the cost of electricity, therefore drawing energy from the grid to meet the unmet load should only be done when absolutely necessary, typically when prices are lowest. To optimize according to the specified criteria, one may use  $G_I(t)$  as a choice variable, similar to how grid power charges batteries.

## 3. Methodology

### 3.1. Formulation of the Problem

Elastic and inelastic energy consumption are the two main types seen in smart grids, as was previously mentioned. There are appliances in the home that have elastic energy demands, such air conditioners, dishwashing machines, and heaters, and equipment that have inelastic energy demands, like computers, televisions, and lights. The situation of inelastic energy demand is examined in this work. This means that energy needs must be met precisely within time slot

$t$ , or only when they are absolutely necessary. According to [13], the splitter controller has the ability to immediately track energy usage, battery state of charge, power pricing, and renewable energy generation. The amount of renewable energy to be stored in the battery and its charge level are both controlled by separate devices.

### 3.2. Renewable Energy Generation

The generation of renewable energy, denoted as  $S(t)$ , must be stored in the battery before it can be utilized in the next time slot. To avoid the battery from overflowing, a controller is employed to regulate the quantity of generated renewable energy, denoted as  $\gamma(t)$ , that is stored in the battery for every time slot  $t$ . We throw away the renewable energy that remains. Therefore, the limit for the control variable is set to  $\gamma(t)$ .

$$0 \leq \gamma \leq 1 \quad \dots\dots\dots(1)$$

Additionally, a maximum value  $S_{max}$  places a cap on the quantity of renewable energy that can be generated  $S(t)$ . This can be stated mathematically as

$$0 \leq S(t) \leq S_{max} \quad \dots\dots\dots(2)$$

Take advantage of the time-dependent change in power prices by assuming that  $G_b(t)$  is the amount of energy that may be received from the power grid to replenish the battery bank in each time slot  $t$ . What happens to the battery's SOC level  $B(t)$  when time passes is determined by the following equation:

$$B(t + 1) = B(t) - D(t) + \gamma(t)S(t) + G_b(t) \quad (3)$$

In this case,  $D(t)$  represents the amount of energy that must be released from the battery at time  $t$  to satisfy the demand. For every time step, the following limitation establishes a maximum SOC level.

$$D(t) \leq B(t) \leq B_{max} \quad (4)$$

A battery's maximum capacity is denoted by  $B_{max}$ . The amount of energy that can be discharged from the battery is further limited by its maximum discharge level, or  $D_{max}$ .

$$0 \leq D(t) \leq D_{max} \quad (5)$$

Moreover, bounded  $G_{b,max}$  refers to the maximum amount of energy that may be obtained from the power grid during a single battery recharge cycle.

$$0 \leq G_b(t) \leq G_{b,max} \quad (6)$$

The utility company transmits the time-varying power pricing, denoted as  $C(t)$ , to the customer's smart meter at the start of each time slot  $t$ . Generating one's own renewable energy is a cost-free process.  $G_I(t)$  represents the power that is extracted from the electrical system to directly fulfill the energy requirement at time slot  $t$ . The cost of electricity for each time slot  $t$  is calculated as the sum of  $[G_b(t) + G_I(t)]C(t)$  multiplied by  $C(t)$ , as the electric power system supplies all the required electricity and charges batteries.

### 3.3. Control Objective

The purpose of the optimization is to minimize the short-term time-averaged electricity cost, as shown by equation (7), in order to decrease the overall power cost for the customers [18].

$$P = \lim_{T \rightarrow \infty} \frac{1}{T} \sum_{t=0}^{T-1} E\{C(t)[G_I(t) + [G_b(t)]]\} \quad (7)$$

The formula below represents the energy demand that is not able to be recovered in time slot  $t$ .

$$A_{ine}(t) = G_I(t) + D(t) \tag{8}$$

Therefore, the following stochastic optimization objective can be used to define the problem:

$$\min_{D(t), G_b(t), G_I(t), \gamma(t)} P = \lim_{T \rightarrow \infty} \frac{1}{T} \sum_{t=0}^{T-1} E\{C(t)[G_I(t) + [G_b(t)]\} \dots\dots\dots(9)$$

With the following limitations in mind

$$\begin{aligned} B(t + 1) &= B(t) - D(t) + \gamma(t)S(t) + G_b(t) \\ D(t) &\leq B(t) \leq B_{max} \\ D(t) &\leq B(t) \leq B_{max} \\ G_I(t) + D(t) &= A_{ine}(t) \\ 0 &\leq D(t) \leq D_{max} \\ 0 &\leq G_I(t) \leq G_{I,max} \\ 0 &\leq G_b(t) \leq G_{b,max} \\ 0 &\leq \gamma \leq 1 \\ X_{ine}(t) &= B(t) - V_{ine} * C_{max} - D_{max} \dots\dots\dots(10) \end{aligned}$$

$V_{ine}$  is a control parameter that is used to guarantee that the battery's state of charge (SOC) level limitation is satisfied.  $X_{ine}(t)$  represents the battery SOC level  $B(t)$  that has been moved. The battery's state of charge (SOC) for the next time step is calculated by shifting its current SOC level using the given formula.

$$X_{ine}(t + 1) = X_{ine}(t) - D_{max} + \gamma(t)S(t) + G_b(t) \tag{11}$$

The optimization process takes into account the following decision variables: the amount of energy discharged from the battery  $D(t)$ , the power drawn from the grid to directly supply the load  $G_I(t)$ , the power drawn from the grid to charge the battery  $G_b(t)$ , and the control parameter  $\gamma(t)$  that determines the amount of renewable energy to store in the battery. Genetic Algorithms are utilized for optimization purposes.

## 4. Results and discussion

### 4.1. Algorithm: Adaptive Predictive Control for Smart Grid Optimization (APCSGO)

#### 4.1.1. Overview

By combining adaptive control mechanisms, real-time monitoring, and predictive analytics, the Adaptive Predictive Control for Smart Grid Optimization (APCSGO) algorithm aims to improve Gabon's smart grid's sustainability and efficiency. To reduce energy losses and operating expenses, the algorithm continuously evaluates real-time data, projects future grid circumstances, and makes dynamic adjustments to operations.

#### 4.1.2. Steps

##### Data Collection and Integration

Gather up-to-date information from several sources, such as weather stations, smart meters, grid sensors, and renewable energy sources.

Transfer this information to a consolidated data management platform.

##### Prediction Modeling

Create prediction models for energy demand, supply variations, and grid performance using machine learning approaches.

To increase accuracy, train the models with historical data and keep them updated with real-time data.

##### Real-Time Monitoring

Set up a system that continuously monitors the grid's condition in real time.

Identify irregularities, errors, and inadequacies instantly.

##### Adaptive Control Mechanisms

It involves creating algorithms that can modify grid operations in real time by using predictive insights and real-time data.

To determine the best control actions, apply optimization techniques such genetic algorithms, dynamic programming, and linear programming.

##### Energy Loss Detection and Mitigation

To find areas of energy loss, apply sophisticated fault and anomaly detection algorithms.

To reduce energy losses, use proactive maintenance plans and real-time corrective procedures.

##### Cost Optimization

To reduce operating expenses, create cost-optimization methods that make use of predictive insights.

Make the most of renewable energy sources and effectively handle peak demand.

##### Decision Support System

Develop approachable dashboards and tools that give grid operators and legislators useful information.

Enable well-informed decision-making through the utilization of predictive analytics and real-time data.

##### Feedback Loop

Establish a feedback loop in which the results of control operations are tracked and utilized to improve the control algorithms and predictive models.

Assure ongoing enhancement and adjustment to evolving grid circumstances.

#### 4.1.3. Pseudocode

##### # Step 1: Data Collection and Integration

```
data = collect_real_time_data(sources=['smart_meters', 'grid_sensors', 'weather_stations', 'renewable_sources'])
centralized_data_system = integrate_data(data)
```



```

# Step 2: Predictive Modeling predictive_
model      =      train_predictive_model(centralized_data_system.historical_data)      real_time_predictions      =
predictive_model.update(centralized_data_system.real_time_data)

#Step 3: Real-Time Monitoring
real_time_monitoring_system = monitor_grid(centralized_data_system.real_time_data)

anomalies = real_time_monitoring_system.detect_anomalies()

# Step 4: Adaptive Control Mechanisms
optimal_control_actions = adaptive_control(real_time_predictions, anomalies)

execute_control_actions(optimal_control_actions)

# Step 5: Energy Loss Detection and Mitigation
energy_losses = detect_energy_losses(real_time_monitoring_system)

mitigation_actions = schedule_maintenance_and_corrections(energy_losses)

execute_mitigation_actions(mitigation_actions)

# Step 6: Cost Optimization
cost_optimization_strategies = optimize_costs(real_time_predictions, operational_data)

execute_cost_optimization(cost_optimization_strategies)

# Step 7: Decision Support System
dashboard = create_dashboard(centralized_data_system, predictive_model, control_actions, optimization_strategies)

provide_insights_to_operators(dashboard)

# Step 8: Feedback Loop
feedback = collect_feedback(dashboard.outcomes)

refine_models_and_algorithms(feedback)

```

#### 4.1.4. Key Features

- Scalability: As Gabon's smart grid system expands, the algorithm is made to evolve with it.
- Flexibility: Its flexibility allows it to adjust to evolving circumstances and novel technology in the energy industry.
- Real-Time Operation: Real-time operation improves dependability by guaranteeing a prompt reaction to grid conditions.
- The integration of renewable energy sources and efficient resource utilization are given priority in the sustainability focus.
- User-Centric: Assists grid operators and policymakers by offering practical insights via user-friendly dashboards.

The APCSGO algorithm can help Gabon's smart grid meet its energy targets by increasing sustainability, lowering energy losses, and improving efficiency.

## 4.2. Optimization Algorithm

Currently, stochastic and deterministic algorithms are the two main forms of optimization algorithms that are commonly utilized. Deterministic algorithms utilize explicit rules to transition between responses, while stochastic algorithms employ probabilistic translation rules. The Directed, Parallel, Stochastic Genetic Algorithm (GA) is a highly

utilized method for global search and optimization, with a wide range of applications. The fundamental principles of natural evolution encompass species diversity, natural selection, and reproduction. Genetic Algorithm (GA) belongs to the category of Evolutionary Algorithms (EA).

#### 4.3. Genetic Algorithm (GA)

is an optimization algorithm with a bio-inspired design that is based on biological genetics [14]. In essence, this search algorithm combines the chance of inheriting the genes (in offspring) with the natural phenomenon of gene division (from parents) to identify the best/optimal answer [15]. The algorithm finds the most fit individual by utilizing a population, or group of people, and their chromosomes, or traits. To mix the traits between the parents, the process entails gene crossing over and mutation (a single trait or value from a chromosome). Every parent population multiplies to create a new population of offspring that is more mutated and has higher fitness values than its parents. Every iteration of this evolutionary method yields better parameter values, and the process is repeated until the required end-conditions (optimal values) are met. The genetic algorithm's flow chart is displayed in Figure 3. A population of chromosomes or a generation a collection of potential answers is used to initialize the algorithm. Each person's chromosomes make up the generation, which is assessed to determine its quality. In order to discover the best answers, chromosomal features are modified by cross-over and mutation from a random sample of individuals in the community. Until the intended outcomes are achieved without any weak chromosomal characteristics, the process is repeated.

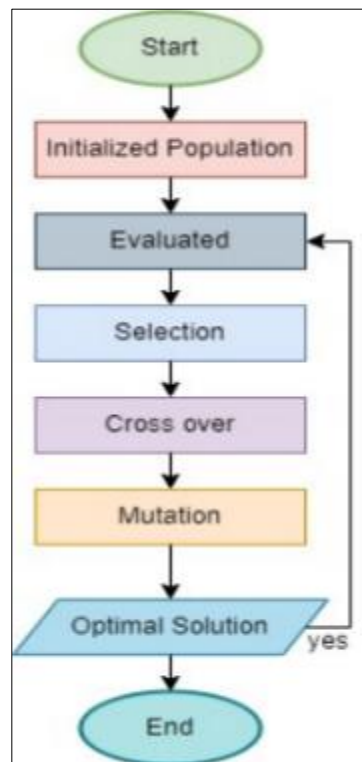

**Figure 3** Flow chart of the genetic algorithm

This study suggests using the decision factors from the preceding section to minimize the time-averaged cost of power. Below is a detailed description of the multi-variable single aim Genetic Algorithm.

- Initialization A population of individuals,  $x$ , is randomly formed with a size of  $N$ . Each individual is generated inside the specified boundaries of each variable.
- Evaluation: After the population is initialized or a new population is created, the fitness function (objective) is calculated.
- Selection: The selection process distributes additional copies of the candidate solutions that have higher fitness values, using the survival-of-the-fittest technique. Several selection methods exist, including ranking, tournament selection, stochastic universal, and roulette-wheel. In this study, the selection of the roulette wheel is based on its ranking. The individuals are evaluated based on their fitness values after being organized. The probability of each individual's selection is determined using the subsequent non-linear function:

$$P = \beta(1 - \beta)(rank - 1) \tag{12}$$

A user-defined coefficient is denoted by  $\beta$ . The most appropriate candidates are now chosen using the conventional roulette wheel procedure.

- **Recombination:** Crossover, often referred to as recombination, is the act of merging components from two or more parental solutions to generate new offspring solutions, which may potentially be superior. This work uses the blend crossover (BLX) -  $\alpha$  crossover operator. After the crossover, the child is selected by considering the traits of both parents and is then provided by

$$x_i^{(1,t+1)} = (1 - \gamma_i)x_i^{(1,t)} + \gamma_i x_i^{(2,t)} \tag{13}$$

Where,  $\gamma_i = (1 + 2\alpha)u_i - \alpha$ , in which  $u_i$  is a random number between 0 and 1.

- **Mutation:** A solution is altered locally and randomly by mutation, whereas recombination modifies a solution on two or more parental chromosomes. In this work, non-uniform mutation is employed, and the resulting mutated offspring are provided by

$$y_i^{(1,t+1)} = x_i^{(1,t+1)} + \tau(x_i^{(U)} - x_i^{(L)})(1 - r^{(1-\psi_{max})^b}) \dots\dots\dots(14)$$

Where the maximum number of allowed generations is denoted by  $t_{max}$ ,  $\tau$  takes a Boolean value of either  $-1$  or  $1$ , and  $b = 0.5$  is a parameter set by the user.

- **Merged Population:** To maintain elitism, the populations of parents and children are merged and then sorted according to fitness levels. For the following generation, the first N people are selected.
- **Iterate:** Repeat steps 2 through 6 until the fitness value converges or the termination condition is satisfied.
- **Input Data:** The input data for this study is derived from the average hourly electricity prices, denoted as  $C(t)$ , throughout a 24-hour period. Fig. 3 displays the information obtained from the California Independent System Operator (CAISO). Figure 4 [16] displays the average renewable energy statistics obtained from the Measurement and Instrumentation statistics Center (MIDC) at the National Renewable Energy Laboratory. Figure 4 illustrates the non-flexible load during a 24-hour period [17], which is determined by the energy consumption of appliances at each time slot  $t$ . The GA optimization is conducted with The next section presents the discoveries.

$$D_{max} = 30KW, G_{I,max} = 30KW \text{ and } G_{b,max} = 20kw \dots\dots\dots[18].$$

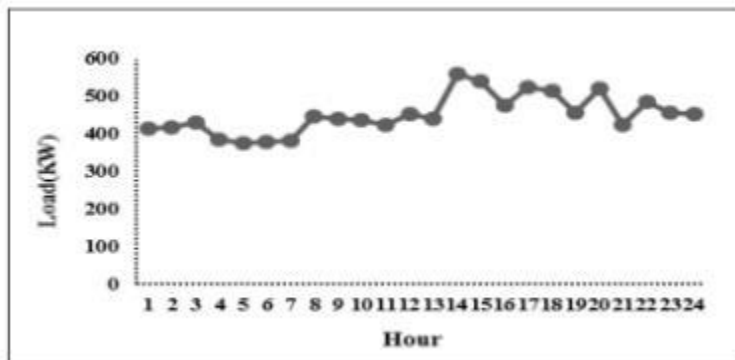

**Figure 4** Average hourly workload for a full day

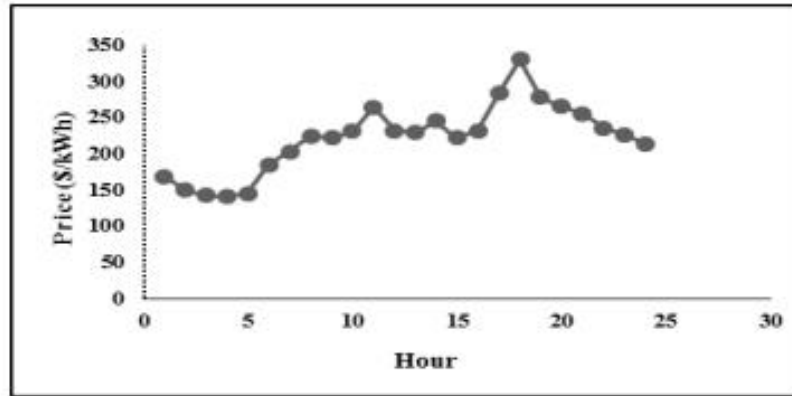

Figure 5 The 24-hour average of the hourly market price

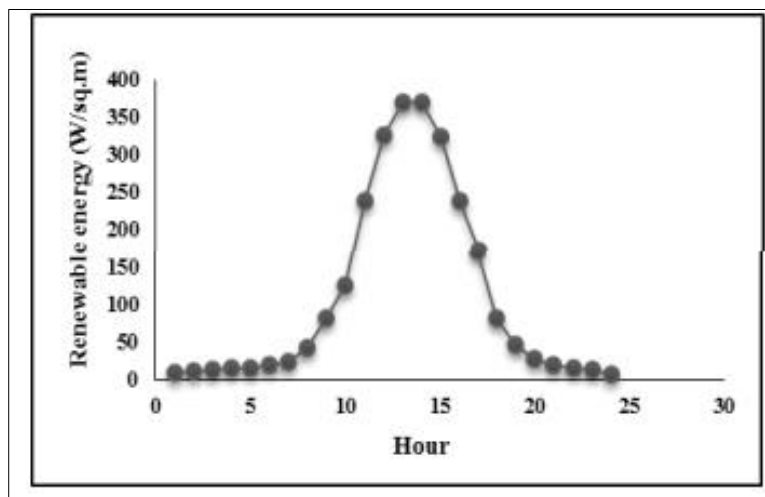

Figure 6 24-hour average of renewable energy per hour

- Performance Evaluation: This study utilizes the 24-hour data on renewable energy, electricity pricing, and inelastic energy demand discussed in the previous section to suggest and run a multi-variable, single-objective evolutionary algorithm. MATLAB is utilized to simulate the optimization of the short-term time-averaged electricity cost for various values of  $B_{max}$ . Table 1 lists the ideal fitness values for the  $B_{max} = \{100, 150, 200\}$ -slot, which are also displayed in Fig. 5. The overall cost of power is found to be highest at  $B_{max} = 100$  and lowest at  $B_{max} = 200$ , according to the data. It follows that increasing the capacity of the battery banks reduces the overall cost of electricity for users.

Table 1 Different  $B_{max}$  values' fitness values for inelastic energy demand

Iteration	Time Average Electricity Cost		
	$B_{max} = 100KW$	$B_{max} = 150KW$	$B_{max} = 200KW$
1	0.530760	0.187680	0.642621
2	0.206573	0.187680	0.642621
3	0.074108	0.187680	0.642621
4	0.074108	0.187680	0.642621
5	0.074108	0.187680	0.642621

6	0.074108	0.187680	0.642621
7	0.041002	0.187680	0.642621
8	0.041002	0.187680	0.510156
9	0.041002	0.121448	0.427366
10	0.041002	0.121448	0.377701
11	0.041002	0.10706	0.030071
12	0.041002	0.055215	0.08030
13	0.041002	0.055215	0.08030
14	0.041002	0.055215	0.08030
15	0.041002	0.055215	0.080306
16	0.041002	0.02210	0.080306
17	0.041002	0.02210	0.080306
18	0.041002	0.02210	0.080306
19	0.041002	0.000083	0.014064
20	0.041002	0.000083	0.014064
21	0.040057	0.000083	0.014064
22	0.040057	0.000083	0.014064
23	0.040022	0.000083	0.007861
24	0.038601	0.087520	0.007861
25	0.038601	0.084843	0.007861
26	0.037887	0.084843	0.007506
27	0.037887	0.084843	0.007506
28	0.037887	0.082887	0.000227
29	0.037887	0.082887	0.000227
30	0.037887	0.082773	0.000227
31	0.036852	0.082773	0.000227
32	0.036852	0.082227	0.000227
33	0.036852	0.080817	0.000227
34	0.036852	0.080704	0.000227
35	0.036852	0.064680	0.000227
36	0.036852	0.064145	0.000227
37	0.036852	0.014470	0.000227
38	0.036852	0.014470	0.000227
39	0.035424	0.014470	0.000227
40	0.034783	0.014470	0.000227
41	0.034783	0.014470	0.000227
42	0.034783	0.014470	0.000227
43	0.034202	0.001567	0.000227

44	0.034202	0.001567	0.000227
----	----------	----------	----------

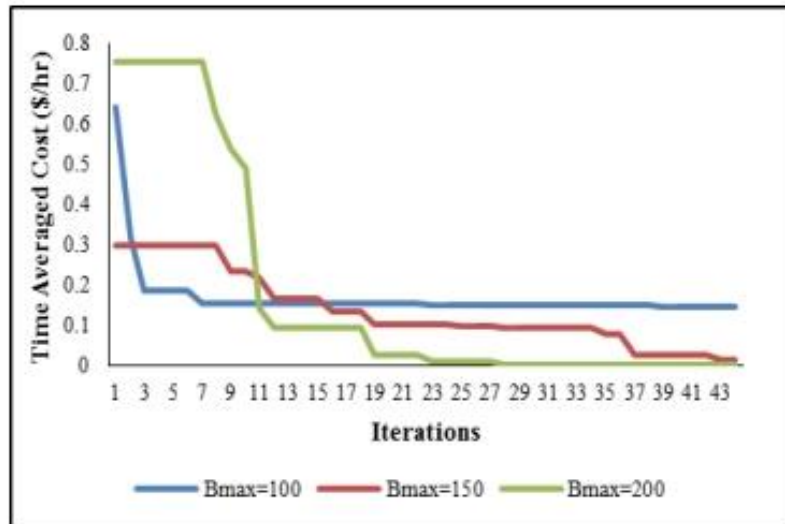

**Figure 8** Comparison of the overall costs with inelastic energy demand for various  $B_{max}$  values

## 5. Conclusion

For consumers with inelastic demand in a smart grid, reducing the average power cost over a short period of time is the most efficient way to minimize the total electricity cost. Due to their time-specific nature, batteries are commonly used to provide power to inelastic loads. Batteries are recharged using both renewable energy sources and the electrical grid. The optimization seeks to recharge the battery when electricity rates are low and drain it when electricity rates are high. An optimization process is performed on a 24-hour dataset that includes the real-time power price, the amount of renewable energy generated, and the overall inelastic energy demand of the utilities. This optimization is carried out using a genetic algorithm that considers multiple variables and aims to achieve a single target. Three different battery capacities were analyzed to determine the ideal minimal cost. The analysis revealed a negative correlation between battery capacity and overall electricity prices, meaning that larger battery capacities were associated with lower electricity prices, while smaller capacities were associated with higher prices.

## Compliance with ethical standards

### *Disclosure of conflict of interest*

No conflict of interest to be disclosed.

## References

- [1] Genetic Algorithms by Kumara Sastry, David Goldberg University of Illinois, USA Graham Kendall University of Nottingham, UK.
- [2] An Introduction to Genetic Algorithms by Paul Charbonneau.
- [3] Akinyele, D. O., Rayudu, R. K., & Nair, N.-K. C. (2014). Global progress in photovoltaic technologies and the scenario of development of solar panel plant and module performance estimation – Application in Nigeria. *Renewable and Sustainable Energy Reviews*, 32, 45-59.
- [4] Qin, S. J., & Badgwell, T. A. (2003). A survey of industrial model predictive control technology. *Control Engineering Practice*, 11(7), 733-764.
- [5] Gondomar, M., Vakilian, M., & Ehsan, M. (2005). A Genetic-Based Tabu Search Algorithm for Optimal DG Allocation in Distribution Networks. *Electric Power Components and Systems*, 33(12), 1351-1362.

- [6] Bahramirad, S., Khodaei, A., & Shahidehpour, M. (2012). Optimal Plan for Enhancing Resiliency of a Distribution Grid. *IEEE Transactions on Smart Grid*, 3(2), 884-891.
- [7] Conejo, A. J., Carrion, M., & Morales, J. M. (2010). *Decision Making Under Uncertainty in Electricity Markets*. Springer.
- [8] Liu, C., Zhang, X., & Vasilakos, A. V. (2012). Crowdsourcing for smart grid: A case study on EVs charging. *IEEE Transactions on Industrial Informatics*, 9(2), 206-215.
- [9] Palensky, P., & Dietrich, D. (2011). Demand side management: Demand response, intelligent energy systems, and smart loads. *IEEE Transactions on Industrial Informatics*, 7(3), 381-388.
- [10] Amankwah-Amoah, J. (2015). Solar energy in sub-Saharan Africa: The challenges and opportunities of technological leapfrogging. *Thunderbird International Business Review*, 57(1), 15-31.
- [11] Brown, R. E., & Suryanarayanan, S. (2007). A survey of the impact of smart grid technologies on distribution system reliability. *Proceedings of the IEEE Power & Energy Society General Meeting*, 1-5.
- [12] Momoh, J. A. (2009). *Electric Power System Applications of Optimization*. CRC Press.
- [13] Optimal Power Management of Residential Customers in the Smart Grid by Yuanxiong Guo, Miao Pan and Yuguang Fang.
- [14] NREL: Measurement and Instrumentation Data Center, <http://www.nrel.govmidc/>, 2012.
- [15] A.-H. Mohsenian-Rad and A. Leon-Garci, "EnergyInformation Transmission Tradeoff in Green Cloud Computing," *Proc. IEEE Globe Com '10*, Mar. 2010.
- [16] D. Linden and T. B. Reddy, *Battery Power and Products Technology*, vol. 5, no. 2, pp. 10–12, March/April 2008.
- [17] M. Winter and R. Brodd, *Chemical Reviews*, vol. 104, 4245–4270, 2004.
- [18] Tackling Real Coded Genetic Algorithms: Operators and Tools for Behavioural Analysis by F. HERRERA, M. LOZANO & J.L. VERDEGAY Department of Computer Science and Artificial Intelligence University of Granada, Avda. Andalucia 38, 18071 Granada, Spain.
- [19] *Time-Varying Retail Electricity Prices: Theory and Practice* by Severin Borenstein.
- [20] California ISO Open Access Same-Time Information System (OASIS), <http://oasis.caiso.com/>, 2012.
- [21] NREL: Measurement and Instrumentation Data Center, <http://www.nrel.govmidc/>, 2012.
- [22] R. Urgaonkar, B. Urgaonkary, M.J. Neely, and A. Sivasubramaniam, "Optimal Power Cost Management Using Stored Energy in Data Centers," *Proc. ACM Int'l Conf. Measurement and Modeling of Computer Systems (SIGMETRICS '11)*, June 2011.
- [23] *Dynamic Programming and Optimal Control Volume I THIRD EDITION* by P. Bertsekas Massachusetts Institute of Technology.
- [24] *Dynamic Programming and Optimal Control 3rd Edition, Volume II* by Dimitri P. Bertsekas Massachusetts Institute of Technology.
- [25] *Resource Allocation and Cross Layer Control in Wireless Networks* by Leonidas Georgiadis, Michael Neely and Leandros Tassiulas.
- [26] *Optimal Power Cost Management Using Stored Energy in Data Centers* by Rahul Urgaonkar, Bhuvan Urgaonkar, Michael J. Neely, Anand Sivasubramanian.
- [27] Genetic Algorithm Performance with Different Selection Strategies in Solving TSP, *Proceedings of the World Congress on Engineering 2011 Vol II WCE 2011*, July 6 - 8, 2011, London, U.K by Noraini Mohd Razali, John Geraghty.
- [28] R. L. Wang, A genetic algorithm for subset sum problem, *Neurocomputing*, vol.57, pp.463-468, 2004.
- [29] *Selection Schemes, Elitist Recombination and Selection Intensity* by Dirk Thierens Department of Computer Science Utrecht University.
- [30] BASIC- A genetic algorithm for engineering problems solution, *Institute of Chemical Engineering, Bulgarian Academy of Sciences* by Elisaveta G. Shopova, Natasha G. Vaklieva-Bancheva.
- [31] California ISO Open Access Same-Time Information System (OASIS), <http://oasis.caiso.com/>, 2012